



# AP220D5

## 50 Hz Diesel Generator

**3**

Phase

**220**

kVA Standby

**200**

kVA Prime

**50**

Hz

**400**

V



\*Image for illustration purposes only, actual product may differ

Output Power	kVA	kW
Standby Power (ESP)	220	176
Prime Power (PRP)	200	160

Size	L x W x H (mm)	Weight (kg)	Fuel Tank (lt)	Noise dB(A) @ 7m
Canopied	3860 x 1200 x 1850	2235	330	70
Open Skid	2700 x 1200 x 1470	1694	330	N/A

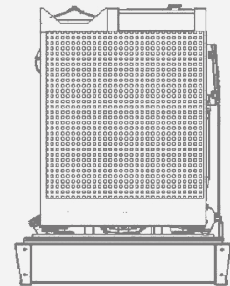
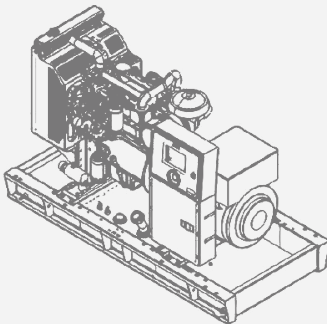

### Continuous Power

The rated power of a generating set represents the maximum continuous power it can deliver while providing a constant electrical load. The average load can reach 100%. However, it is crucial not to overload the generator to ensure its optimal performance and longevity.

### Standby Power

The maximum available power during a variable electrical power sequence, under specified operating conditions, refers to the generating set's capacity to deliver power in the event of a utility power outage.

### Prime Power

The rated power of a generating set represents the utmost capacity it can consistently deliver while accommodating a variable electrical load. It is recommended to maintain an average load of 70% for optimal performance. However, the generator can handle brief overloads of up to 10% for a duration of 1 minute.

**VIEW ONLINE**



14 Lanthwaite Business Park,  
South Kirkby, Pontefract,  
WF9 3AP, UK



Copyright © PBE Group, 2024. All rights reserved.

ade-power.com  
enquiries@ade-power.com  
+44 (0) 1977 658 100





# AP220D5

## 50 Hz Diesel Generator

### Engine

Manufacturer	Perkins
Model	1106A-70TAG4
Cylinder Configuration	Inline
No of Cylinders	6
Displacement	7.01 lt
Stroke	135 mm
Bore	105 mm
Compression Ratio	16:1
Aspiration	Turbocharge-Intercooler
Governor Type	Electronic
Cooling System	Water
Coolant Capacity	21 lt
Lubrication Oil Capacity	16.5 lt
Electrical System	12 VDC
Speed / Frequency 50 Hz	1500 rpm / 50 Hz
Engine Gross Power (Standby 50 Hz)	196 kW
Fuel Consumption %110 ESP 50 Hz	49.4 lt/h
Fuel Consumption %100 PRP 50 Hz	45.8 lt/h
Fuel Consumption %75 PRP 50 Hz	34.3 lt/h
Fuel Consumption %50 PRP 50 Hz	22.9 lt/h
Exhaust Outlet Temperature 50 Hz	580 °c
Exhaust Gas Flow 50 Hz	36.8 m <sup>3</sup> /min
Combustion Air Flow 50 Hz	13.2 m <sup>3</sup> /min
Cooling Air Flow 50 Hz	282 m <sup>3</sup> /min

### Alternator

No of Phases	3
Power Factor	0.8
No of Bearings	Single
No of Poles	4
No of Leads	6-12
Insulation Class	H-F
Degree of Protection	IP23
Excitation System	AVR (Automatic Voltage Regulator), Brushless





# AP220D5

## 50 Hz Diesel Generator

### Standard Equipments

#### Engine

ADE generators exclusively employ industry-leading engine brands that boast cutting-edge technology and full compliance with ISO 8528, ISO 3046, BS 5514, and DIN 6271 standards. These engines are specifically designed for low fuel consumption while offering precise speed control and seamless integration with the fuel pump. Furthermore, they are equipped with either mechanic or electronic type governors to suit diverse operational requirements.

#### Alternator

We use leading alternator brands with state-of-the-art technology, high quality, and durability. All alternators meet rigorous international standards, such as EC 60034-1, CEI EN 60034-1, BS 4999-5000, VDE 0530, NF 51-100,111, OVE M-10, and NEMA MG 1.22. They feature maintenance-free bearing systems and electronic voltage regulators for precise voltage setting.

#### Control Panel

ADE generator sets feature a standard control panel for comfortable and safe usage. The panel allows easy monitoring of measurements, statistics, operating modes, alerts, and generator condition. Its metal body, made of steel sheet, contains an electronic control module and an emergency stop button, coated with electrostatic powder paint. ADE offers quality standard panels and can also customize designs to meet specific customer requirements.

#### Chassis and Fuel Tank

ADE generator sets feature robust steel chassis for superior durability, capable of bearing the generator's weight. Anti-vibration mounts minimise disturbances, ensuring smooth operation. Lifting lugs facilitate easy transportation and positioning. Custom solutions cater to specific customer preferences.

Generators below 1600 kVA have integrated fuel tanks, optimizing space, while larger sets have separate rectangular fuel tanks. All tanks include level indicators for convenient fuel monitoring. ADE's meticulous design approach guarantees reliable and high-performance generator sets.

#### Cooling System

The system comprises a high-quality industrial-type radiator, an expansion tank, and a cooler fan, meticulously designed to maintain the temperature of the generator set's components at a consistently optimal level. This thoughtful integration ensures the efficient and reliable performance of the generator set throughout its operational lifespan.



\*Image for illustration purposes only, actual product may differ

### Canopy Features

ADE standard canopies' default features are as follows;

- Compatible with 2000/14/EC directives, certified noise emission level,
- 2 or 4 points transport possibility according to cabin size,
- Hidden exhaust inside the canopy,
- Emergency stop button located on the canopy,
- Improved air suction channel to ensure homogenous cooling in the canopy,
- Radiator air outlet and exhaust designed to expel vertically.
- Easy-access cap to add water and antifreeze to the radiator.
- Amplified paint system against corrosion and rust,
- Improved performance in terms of sound insulation,
- Demountable parts that make transportation and maintenance easier.

In addition to our comprehensive standard range of canopies, ADE offers the flexibility to design tailor-made canopies, specifically catering to individual requirements for desired sound levels or dimensions on request. Our team of experts is dedicated to providing customized solutions that perfectly match your unique needs, ensuring a seamless and optimal performance for your generator set.

### Optional Equipments

Some optional equipments that ADE provides with generator Sets;

- Medium voltage alternator,
- Remote radiator applications,
- Automatic fuel filling system,
- Fuel tank, oil pan, dashboard, alternator, coil heaters,
- Alternator with double AVR and PMG,
- Synchronization systems,
- The generator output breaker,
- Grid-generator transfer switches,
- Accordance with the specific volume of demand-insulated cabins,
- Seismic solutions,
- Trailer,
- Remote monitoring.





# AP220D5

## 50 Hz Diesel Generator

### Control Panel Features - DSE-7320

- 4-Line back-lit LCD text display
- Five key menu navigation
- Front panel editing with PIN protection
- Customisable status screens
- Power save mode
- Support for up to three remote display units
- 9 configurable inputs
- 8 configurable outputs
- Flexible sender inputs
- Configurable timers and alarms
- 3 configurable maintenance alarms
- Multiple date and time scheduler
- Configurable event log (250)
- Tier 4 CAN engine support
- Integral PLC editor
- Easy access diagnostic page
- CAN and Magnetic Pick-up/Mt. sensing
- Fuel usage monitor and low fuel alarms
- Charge alternator failure alarm
- Manual speed control (on compatible CAN engines)
- Manual fuel pump control
- Engine exerciser
- "Protections disabled" feature
- kW & kV k protection
- Reverse power (kW & kV k) LED and LCD alarm indication
- Power monitoring (kW h, kV h, kV Ah, kV k h)
- Load switching (load shedding and dummy load outputs)
- Automatic load transfer (DSE7320)
- Unbalanced load protection
- Independent Earth Fault trip
- USB connectivity
- Backed up real time clock
- Fully configurable via DSE Configuration Suite PC software
- Configurable display languages
- Remote SCADA monitoring via DSE Configuration Suite PC software
- User selectable RS232 and RS485 communications
- Configurable Gencomm pages
- Advanced SMS messaging (additional external modem required)
- Start & stop capability via SMS messaging
- Additional display screens to help with modem diagnostics
- Idle control for starting & stopping.
- DSENet® expansion compatible
- Heated display option available



DSE DEEP SEA ELECTRONICS

### Functions

- AMF unit
- Remote start controller
- Manual start controller
- Engine controller
- Remote display & control unit
- CTs at genset or load side

### Communications

- Web monitoring
- GSM-SMS (required externally modem)
- e-mail
- USB Device
- RS-232
- J1939-CANBUS

### Topologies

- 2 phase 3 wires, L1-L2
- 2 phase 3 wires, L1-L3
- 3 phase 3 wires
- 3 phase 4 wires, star
- 3 phase 4 wires, delta
- 1 phase 2 wires





# AP220D5

## 50 Hz Diesel Generator



### WARRANTY CERTIFICATE DURATION

Manufacturers warranty applies to new diesel generator sets to be free from defects in material and workmanship in production for 24 months or 1000 hours from the date of delivery to first user (which occurs first). Warranty period is limited by 30 months from the date of shipment ex-works.

### DISCLAIMER AND LIABILITY STATEMENT

Please read this disclaimer carefully before using this data sheet. By accessing and using the information provided in this data sheet, you agree to the terms and conditions outlined below.

- 1. Accuracy of Information:** The information provided in this data sheet is for general informational purposes only. While we strive to ensure the accuracy, completeness, and reliability of the content, we make no warranties or representations regarding its accuracy or suitability for any particular purpose. Users are advised to verify the data and seek professional advice if needed.
- 2. No Endorsement or Recommendation:** The inclusion of any products, services, or third-party information in this data sheet does not imply endorsement or recommendation by us. Any use or reliance on such information is at your own risk.
- 3. Use at Your Own Risk:** Your use of this data sheet and its information is at your own risk. We shall not be held liable for any direct, indirect, incidental, consequential, or special damages, losses, or consequences arising from the use or misuse of this data sheet.
- 4. No Legal or Professional Advice:** This data sheet is not intended to provide legal, financial, technical, or professional advice. Users should seek advice from qualified experts in specific areas as necessary.
- 5. Changes and Updates:** We reserve the right to make changes or updates to the content of this data sheet without prior notice. However, there is no obligation to do so.
- 6. Indemnification:** By using this data sheet, you agree to indemnify and hold us harmless from any claims, liabilities, damages, or expenses arising from your use or reliance on the information provided herein.
- 7. No Contractual Obligations:** This data sheet does not create any contractual relationship between us and the user.
- 8. Applicable Law:** This disclaimer is governed by the laws of the United Kingdom, and any legal disputes or claims shall be subject to the exclusive jurisdiction of the courts in United Kingdom.

By continuing to access and use this data sheet, you acknowledge that you have read and understood this disclaimer and Liability Statement, and you agree to be bound by its terms.

If you do not agree with this disclaimer, you must not use this data sheet or its information.

ADE Power Limited  
ISSUE 02

